

# *EagleSmart*

## ES2400, ES2403, ES4800, ES6000



## USER'S MANUAL

V2.3 – August 2006

[www.eagletronicchargers.com](http://www.eagletronicchargers.com)

# INDEX

· <b>1. SAFETY INSTRUCTIONS AND WARNINGS.....</b>	<b>3</b>
· GENERAL.....	3
· SHOCK PREVENTION.....	3
· BURN AND BODILY INJURY PREVENTION.....	4
· FIRE AND EXPLOSION PREVENTION.....	4
· ARCING AND BURNING OF CONNECTOR.....	4
· MEDICAL AND FIRST AID TREATMENT.....	4
· <b>2. DESCRIPTION OF THE CHARGER.....</b>	<b>5</b>
· <b>3. INSTALLATION OF THE CHARGER.....</b>	<b>5</b>
· AC INPUT CONNECTION.....	6
· AC INPUT VOLTAGE SETTINGS.....	6
· <b>4. HOW TO USE THE CHARGER.....</b>	<b>8</b>
· PROGRAMMATION OF THE FINISHING CHARGE TIME.....	8
· BATTERY CONNECTION – AUTOMATIC VOLTAGE CHECK AND AUTOSTART....	9
· CHARGE OPERATION.....	9
· OVERVOLTAGE PROTECTION.....	10
· SAFETY TIMER – EMERGENCY STOP.....	10
· AUTOMATIC DATA SAVING.....	11
· OVERCURRENT/SHORT CIRCUIT .....	11
· SHUTDOWN ON BATTERY DISCONNECTION.....	11
· MANUAL CHARGE TERMINATION.....	12
· EQUALIZATION.....	12
· QUICK TEST FUNCTION.....	13

# 1. SAFETY INSTRUCTIONS AND WARNINGS

Before to start using your *EagleSmart* battery charger, please take the time to read these instructions carefully.

The owner's manual is an important part of the charger. It's recommended to keep it in good condition for the lifetime of the charger. It should be kept in a dry and clean place, always available to the users.

To indicate important instructions, the following blocks are used throughout this manual.

## CAUTION!

**This operation can be dangerous for the user.**

## ATTENTION!

**This operation is important for the functionality and reliability of the charger.**

## GENERAL

Battery charging products can cause serious injury or death, or damage to other equipment or property, if the operator does not strictly observe all safety rules and take precautionary actions.

Safe practices must be learned through study and training before using this equipment. Only qualified personnel should install, use, or service this equipment.

## SHOCK PREVENTION

Bare conductors, or terminals in the output circuit, or ungrounded, electrically-live equipments can fatally shock a person. To protect against shock, have competent electrician verify that the equipment is adequately grounded and learn what terminals and parts are electrically HOT.

The body's electrical resistance is decreased when wet, permitting dangerous current to flow through the body. Do not work in damp area without being extremely careful. Stand on dry rubber mat or dry wood and use insulating gloves when dampness or sweat cannot be avoided. Keep clothing dry.

**INSTALLATION AND GROUNDING** - A power disconnect switch must be located at the equipment. Check the data label for voltage and phase requirements. If only 3-phase power is available, connect single-phase equipment to **ONLY TWO WIRES** of the 3-phase line.

**DO NOT CONNECT** the equipment grounding conductor to the third live wire of the 3-phase line as this makes the equipment frame electrically HOT, which can cause a fatal shock.

If a grounding conductor is part of the power supply cable, be sure to connect it to a properly grounded switch box or building ground. If not part of the supply cable, use a separate grounding conductor. Don't remove a ground prong from any plug. Use correct mating receptacles. Check ground for electrical continuity before using equipment. The grounding conductor must be of a size equal to or larger than the size of the line conductors.

**CHARGING LEADS** – Inspect leads often for damage to the insulation. Replace or repair cracked or worn leads immediately. Use leads having sufficient capacity to carry the operating current without overheating.

**BATTERY TERMINALS** – Do not touch battery terminals while equipment is operating.

**SERVICE AND MAINTENANCE** – Shut OFF all power at the disconnect switch or line breaker BEFORE inspecting, adjusting, or servicing the equipment. Lock switch OPEN (or remove line fuses) so that the power cannot be turned ON accidentally.

Disconnect power to equipment if it is to be left unattended or out of service. Disconnect battery from charger. Keep inside parts clean and dry. Dirt and/or moisture can cause insulation failure. This failure can result in high voltage at the charger output.

### **BURN AND BODILY INJURY PREVENTION**

The battery produces very high currents when short circuited, and will burn the skin severely if in contact with any metal conductor that is carrying this current.

Do not permit rings on fingers to come in contact with battery terminals or the cell connectors on top of the battery. Battery acid is very corrosive. Always wear correct eye and body protection when near batteries.

### **FIRE AND EXPLOSION PREVENTION**

When batteries are being recharged, they generate hydrogen gas that is explosive in certain concentrations in air (the flammability or explosive limits are 4.1% to 72% hydrogen in air). The spark-retarding vents help slow the rate of release of hydrogen, but the escaping hydrogen may form an explosive atmosphere around the battery if ventilation is poor.

The ventilation system should be designed to provide an adequate amount of fresh air for the number of batteries being charged. This is essential to prevent an explosion.

Always keep sparks, flames, burning cigarettes, and other sources of ignition away from the battery recharging area. Do not break "live" circuits at the terminals of batteries. Do not lay tools or anything that is metallic on top of any battery.

### **ARCING AND BURNING OF CONNECTOR**

To prevent arcing and burning of the connector contacts, be sure the charger is OFF before connecting or disconnecting the battery. The ammeter should NOT indicate current flow.

### **MEDICAL AND FIRST AID TREATMENT**

First aid facilities and a qualified first aid person should be available for each shift for immediate treatment of electrical shock victims.

**EMERGENCY FIRST AID:** Call physician and ambulance immediately and use First Aid techniques recommended by the American Red Cross.

#### **DANGER: ELECTRICAL SHOCK CAN BE FATAL.**

If person is unconscious and electric shock is suspected, do not touch person if he or she is in contact with charging equipment, battery, charging leads, or other live electrical parts. Disconnect power at wall switch and then use First Aid.

Dry wood, wooden broom, and other insulating material can be used to move cables, if necessary, away from person.

**IF BREATHING IS DIFFICULT,** give oxygen.

**IF NOT BREATHING, BEGIN ARTIFICIAL BREATHING,** such as mouth-to-mouth.

**IF PULSE IS ABSENT, BEGIN ARTIFICIAL CIRCULATION,** such as external heart massage.

In case of acid in the eyes, flush very well with clean water and obtain professional medical attention immediately.

## 2. DESCRIPTION OF THE CHARGER

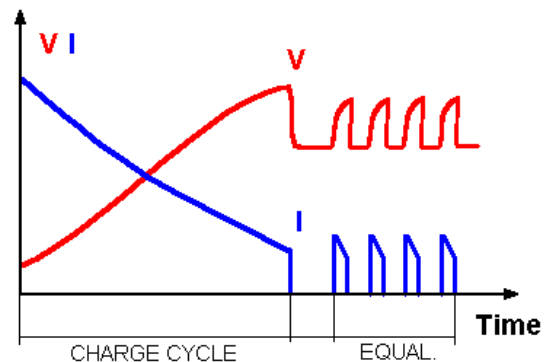

*EagleSmart* battery chargers have been designed to charge Lead-Acid batteries. These units convert the AC input to a DC output at the correct voltage. The charge curve is  $W_a$ , with programmable finishing charge time and automatic equalization.

The operation of the *EagleSmart* chargers is managed by the new MRG Charge Controller, which is a microprocessor based electronic board of the last generation. The MRG Charge Controller monitors the entire charging curve, and it incorporates several safety features.

The front panel of the MRG charge controller is composed by 4 status LEDs (CHARGING – 80% CHARGED – COMPLETE – FAULT! / ALARM !) and 3 ammeter LEDs.

## 3. INSTALLATION OF THE CHARGER

Conditions of use:

- Operating temperature: 5°C to 45°C
- Storage temperature: -20°C to 60°C
- Relative humidity: less than 75%

### CAUTION!

**Risk of electrical shock!**  
The charger can be installed by qualified personnel only.

To prevent fire or shock hazard, do not expose the unit to rain or moisture.  
Don't use the unit in presence of flammable gas, because it can generate sparks.

**ATTENTION!**

**Make sure that the unit's maximum input power (reported on the data label) is available from your power supply, and verify that the unit's operating voltage is correct.**  
**Allow adequate air circulation to prevent internal heat buildup.**  
**Don't place the unit near heat sources such as radiators or air ducts, or in a place subject to direct sunlight, excessive dust, mechanical vibration or shock.**

**AC INPUT CONNECTION**

The charger must be connected to the AC input using an adequate cable and plug, with disconnect switch and fuses.

The AC input wires have to be connected to the **TERMINAL BLOCKS FOR AC INPUT CABLE**, that are located on the right side of the internal panel, just under the AC input contactor (see picture on the next page).

Make sure to tighten the terminal block screws with the right torque, and pull each wire separately in order to verify that they are mounted properly.

**AC INPUT VOLTAGE SETTINGS**

**ATTENTION!**

**The proper setting of the power transformer taps is fundamental for the correct operation of the *EagleSmart* chargers.**

**If the real AC input voltage is different than the AC nominal voltage to which the charger is set, the charging current of the charger may be significantly different than the nominal.**

- With reference to the pictures in the next page, find the **POWER TRANSFORMER TAPS** and the label with the list of the 5 **NOMINAL** voltages available, that are located on the left side of the internal panel.

	<b>SR2400</b>	<b>SR2403</b>	<b>SR4800</b>	<b>SR6000</b>
1	1x 250 VAC	3x 250 VAC	3x 500 VAC	3x 620 VAC
2	1x 240 VAC	3x 240 VAC	3x 490 VAC	3x 610 VAC
3	1x 224 VAC	3x 224 VAC	3x 480 VAC	3x 600 VAC
4	1x 208 VAC	3x 208 VAC	3x 460 VAC	3x 575 VAC
5	1x 200 VAC	3x 200 VAC	3x 440 VAC	3x 550 VAC

- Using an adequate AC-voltmeter, measure the value of the **REAL** AC input voltage available at the mounting location of the charger.
- Identify which of the 5 **NOMINAL** voltage values is closest to the **REAL** measured value.
  - Example 1: for a charger ES2400 (singlephase) if the measured voltage is 212 VAC, the transformer should be connected to the tap number 4, that corresponds to 208 VAC.*
  - Example 2: for a charger ES6000 (threephase) if the measured voltage is 608 VAC, the transformer should be connected to the tap number 2, that corresponds to 610 VAC*
- For the singlephase units (**ES2400**), the wires to be moved are the **TWO** that are connected to the AC contactor, marked with the letter **"A"**.

- For the threephase units (ES2403 – ES4800 – ES6000), the wires to be moved are the THREE that are connected to the AC contactors, marked with the letters “A”, “B” and “C”.

***Singlephase units (ES2400)***

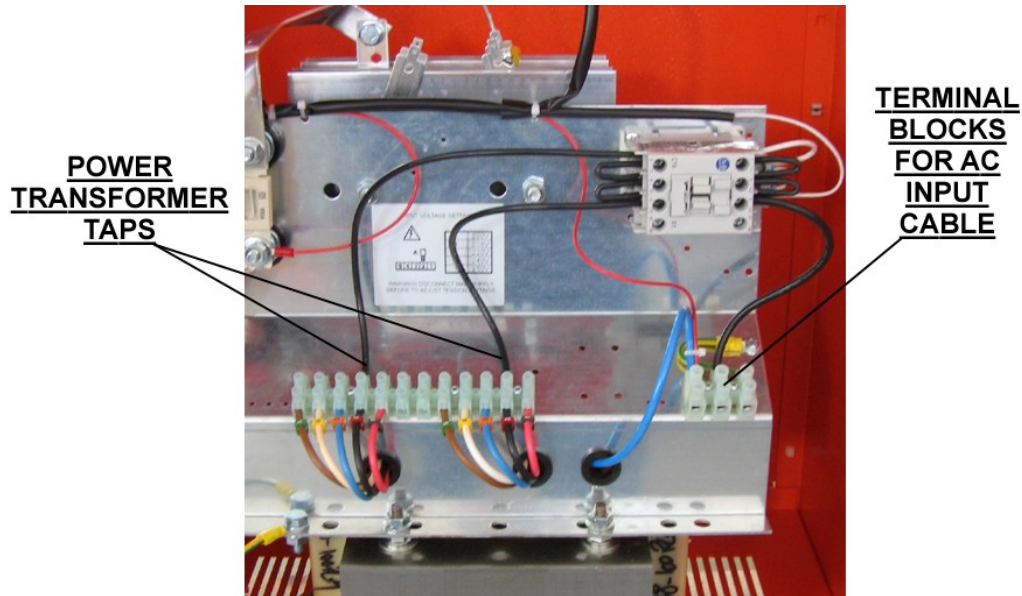

***Threephase units (ES2403 – ES4800 – ES6000)***

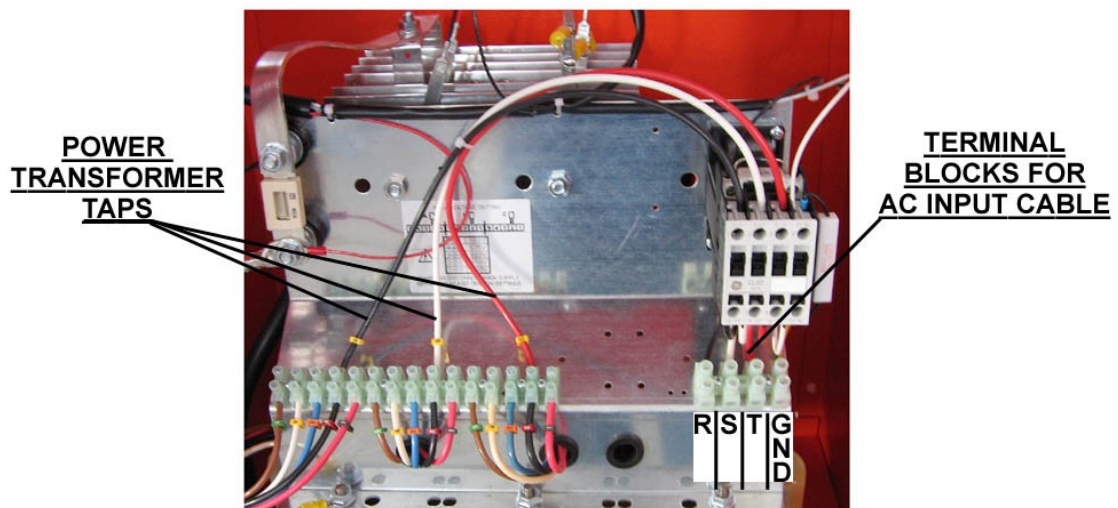

## 4. HOW TO USE THE CHARGER

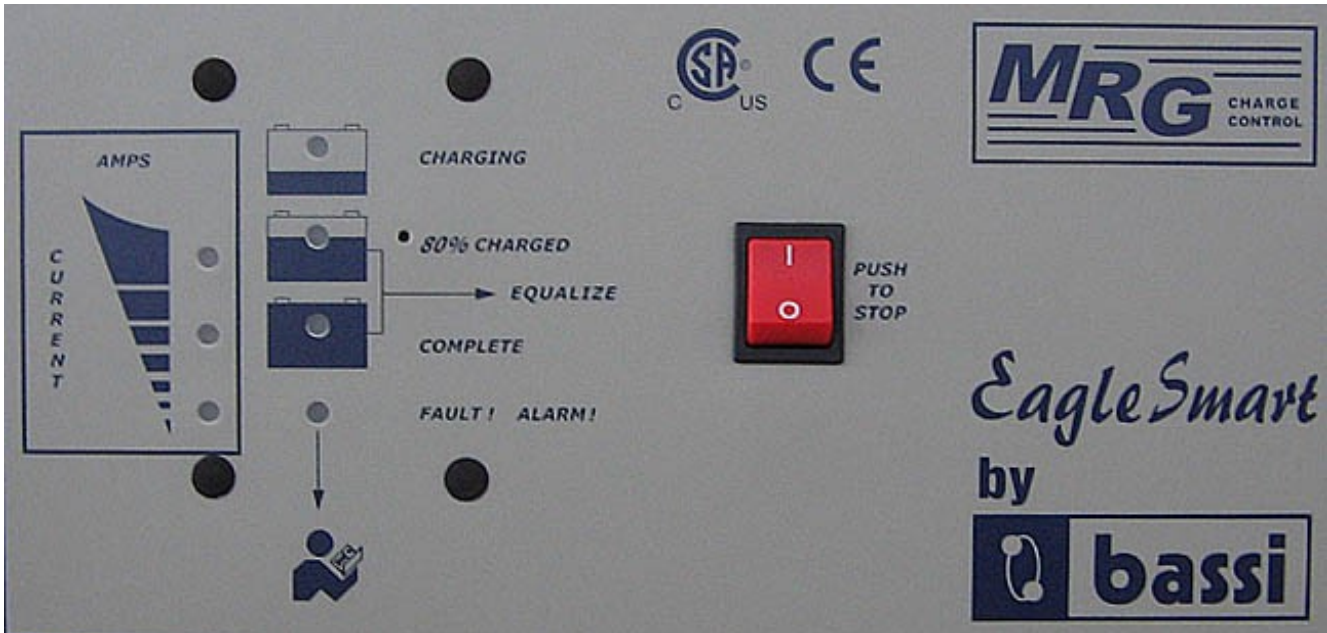

### PROGRAMMATION OF THE FINISHING CHARGE TIME

The programmable finishing charge times are 2 to 12 hours in the MRG Charge Controller. The default value (factory programmed) is 3 hours.

Behind the small hole located near the LED "80% CHARGED", there is a button that is used to program the finishing charge time. This button can be reached using a small object, like a needle, a small screwdriver or a toothpick.

- Disconnect the charger from the AC input.
- Connect a battery. The four status LEDs will blink alternately.
- Push the button for the programming of the finishing charge time to enter the programming mode. Only one LED will blink. This LED corresponds to the finishing charge time that was previously programmed, with reference to the picture on the right.
- Push the button again to move the blinking LED to the desired position.
- Wait for 5 seconds. The charger will return to normal mode, and the four status LEDs will blink alternately.
- Disconnect the battery.

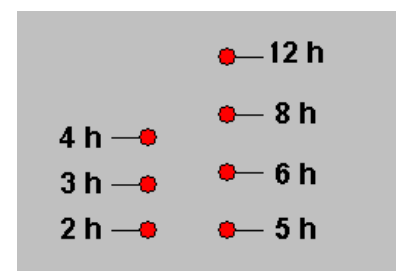



**BATTERY CONNECTION – AUTOMATIC VOLTAGE CHECK AND AUTOSTART****ATTENTION!**

*EagleSmart* chargers are programmed to do a complete cycle of charge automatically, however it's recommended to survey the operation of the charger when the battery remains connected to the charger for more than 12 hours.

Connect the battery to the charger, using an adequate plug.

When the battery is correctly connected, all the LEDs of the control panel will light on in sequence for a quick check.

If the voltage of the battery is below 1,60 V/cell, the charger will not start, and the MRG front panel will show the error message “Wrong Battery - Voltage Low”.



If the voltage of the battery is higher than 2,50 V/cell, the charger will not start, and the MRG front panel will show the error message “Wrong Battery - Voltage High”.



If the voltage of the battery is in the correct range [1,60 to 2,50 V/cell], the charge will start automatically.

**CHARGE OPERATION**

While the charge is in progress, the 3 LED ammeter will indicate the output current level, while the status LED “Charging” blink continuously.

When the battery will reach the gassing voltage (2,40 V/cell) the status LED “80% Charged” will start blinking, together with the LED “Charging”.

The charge will continue for the programmed finishing time (2 to 12 hours), following the Wa charge curve.

When the charge is complete, the charger switches off automatically, and the MRG front panel will give the message “COMPLETE”:



### OVERVOLTAGE PROTECTION

If, during the charge, the voltage of the battery will increase above 2,80 V/cell, the charger will shut down automatically, and the MRG front panel will show the message “Voltage High”:



### SAFETY TIMER – EMERGENCY STOP

The MRG controller includes a safety timer that shuts the charger down if the battery doesn't reach the gassing voltage within a defined time limit. This time limit is not fixed, but it depends on the finishing time selected by the user.

If this condition occurs, the MRG front panel shows the message “Time Error”:



The cause if this problem may be a wrong setting of the input voltage: if the input is set to a certain value (for example: 610 V) but the real voltage is lower (for example: 575 V), the charging current will be significantly lower than the nominal value, therefore the battery will take too long to reach the gassing voltage.

### **AUTOMATIC DATA SAVING**

If, during the charge or equalization, one or more black-outs of the AC input occur, the microprocessor automatically saves all the relevant informations about the state of the charge. While the input power is absent and the battery is connected to the charger, the MRG Charge Controller will show the message “Black Out” (4 status LEDs blinking alternately).



When the power supply will be available again, the charger will re-start automatically from the exact point of interruption, and the charge will be completed normally.

### **OVERCURRENT/SHORT CIRCUIT PROTECTION**

If the output current exceeds 140% of the rated value, the MRG Charge Controller will shut the charger down immediately, and it will show the message “OVERCURRENT” on the front panel.



### **SHUTDOWN ON BATTERY DISCONNECTION**

#### **CAUTION!**

**NEVER** disconnect the battery while it's being charged.  
Disconnecting the battery while it's being charged is hazardous  
for the user and voids the charger warranty.

If the battery is disconnected while the charge is in progress, the *EagleSmart* charger will switch off automatically.

## MANUAL CHARGE TERMINATION

While the charge is in progress, it's possible to turn off the charger by pressing the red button "STOP". The MRG front panel will show the message "MANUAL STOP".



In this condition, it's safe to disconnect the battery.

## EQUALIZATION

The *EagleSmart* chargers Equalize the battery on a weekly basis. The operation is totally automatic.

After the normal completion of the charge, the *EagleSmart* chargers wait for 15 hours, then it gives 4 equalization cycles of 30 minutes, with 15 hours of interval between each cycle.

While the equalization charge is in progress, the MRG Front Panel shows the message "EQUALIZING":



With this timing system, the equalization is performed only in the weekend, when the battery remains connected to the charger for more than 15 hours after the completion of the charge.

At the end of the equalization, the charger will remain in stand-by mode, while the front panel gives the message "COMPLETE":



## QUICK TEST FUNCTION

### CAUTION!

**Risk of electrical shock!**  
**The charger can be serviced by qualified personnel only.**  
**Before to open the cabinet, disconnect the charger from battery and AC main supply.**

The MRG controller includes a quick test function, that can be enabled by moving a jumper that is located on the board.



QuickTest jumper in position NORMAL

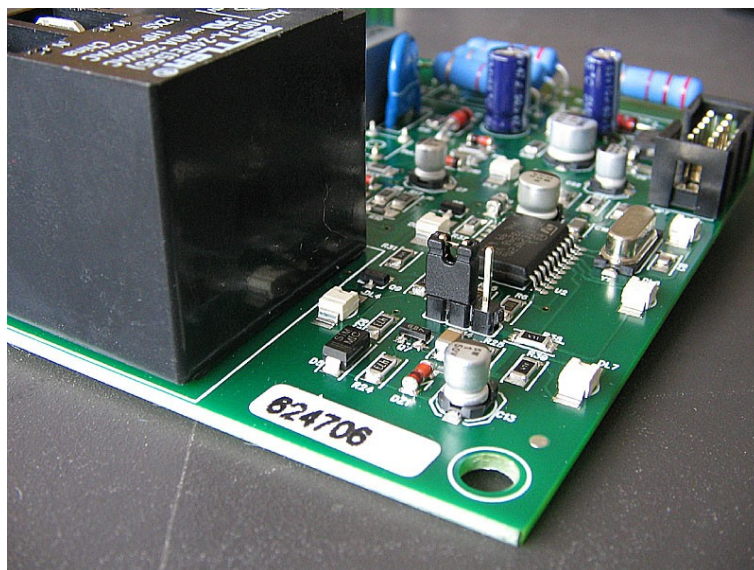

QuickTest jumper in position TEST

**ATTENTION!**

**It's always necessary to keep the battery disconnected while moving the QuickTest jumper.**

When the jumper is set to position **NORMAL**, the MRG controller works normally.

When the jumper is set to position **TEST**, the MRG controller performs the complete charge cycle in seconds, instead of minutes.

When a battery is connected:

- if the voltage is lower than the gassing value, the EagleSmart will go in Emergency Stop after 20-30 seconds.
- If the voltage is higher than the gassing value, the EagleSmart will terminate the charge and pass to the automatic equalize in a few seconds.

**ATTENTION!**

**After performing a quick test cycle, make sure to move the jumper to position **NORMAL** before to put the charger in service.**

**If the QuickTest jumper remains in position **TEST**, each charge cycle will terminate within 20-30 seconds, therefore the battery will not be charged!**

- End of manual -

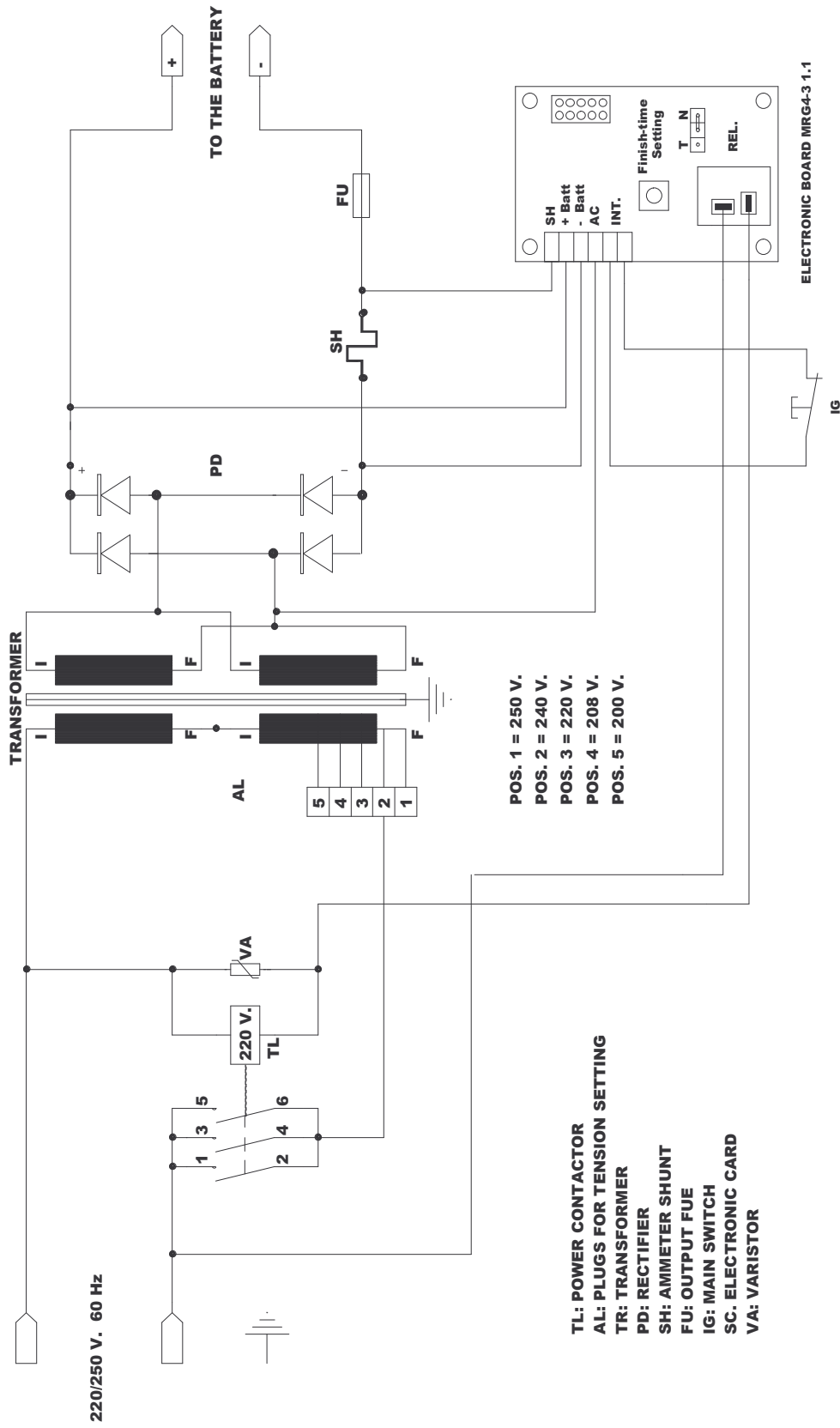

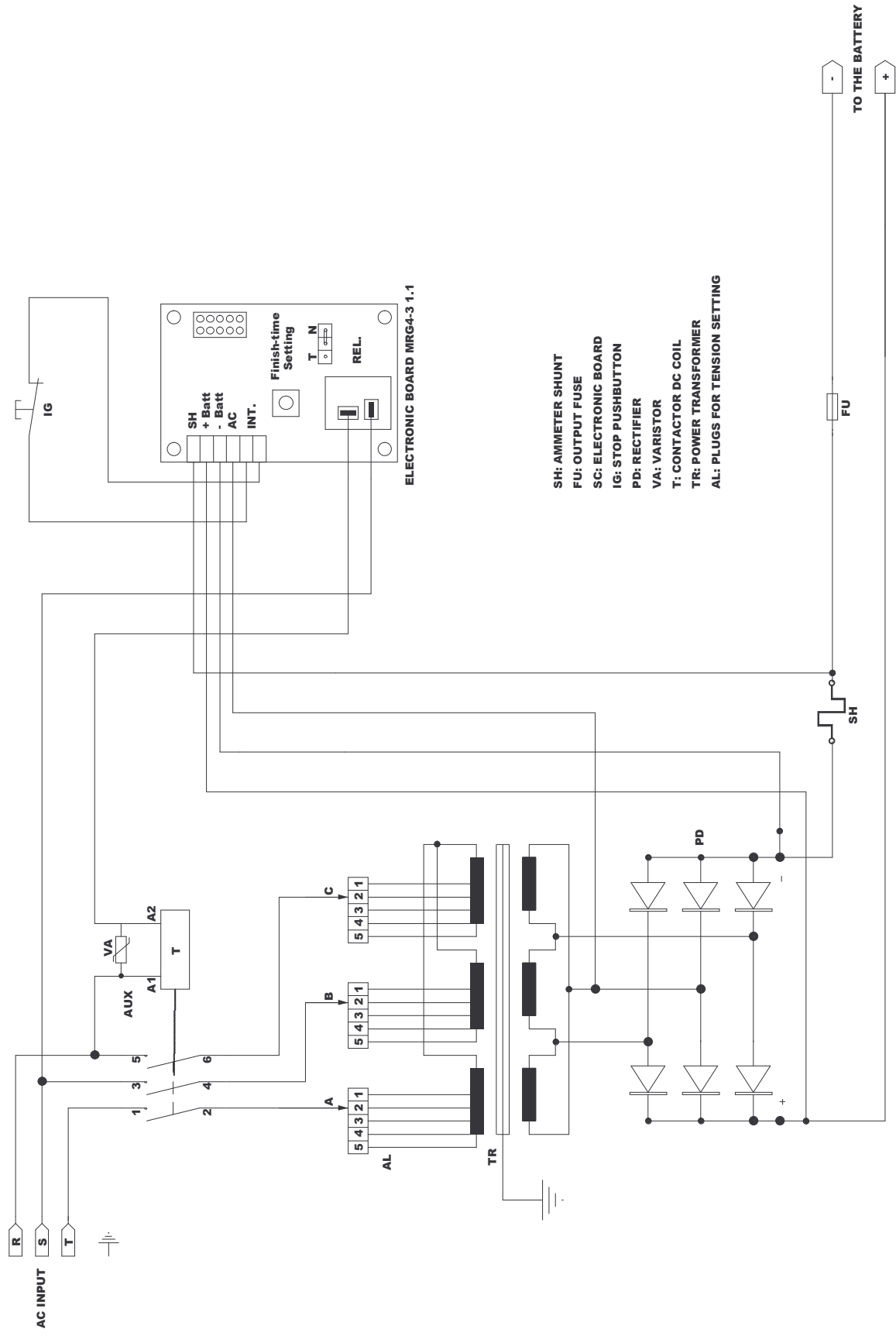

- SH: AMMETER SHUNT
- FU: OUTPUT FUSE
- SC: ELECTRONIC BOARD
- IG: STOP PUSHBUTTON
- PD: RECTIFIER
- VA: VARISTOR
- T: CONTACTOR DC COIL
- TR: POWER TRANSFORMER
- AL: PLUGS FOR TENSION SETTING



- SH: AMMETER SHUNT
- FU: OUTPUT FUSE
- SC: ELECTRONIC BOARD
- IG: STOP PUSHBUTTON
- PD: RECTIFIER
- VA: VARISTOR
- T: CONTACTOR DC COIL
- TR: POWER TRANSFORMER
- AL: PLUGS FOR TENSION SETTING

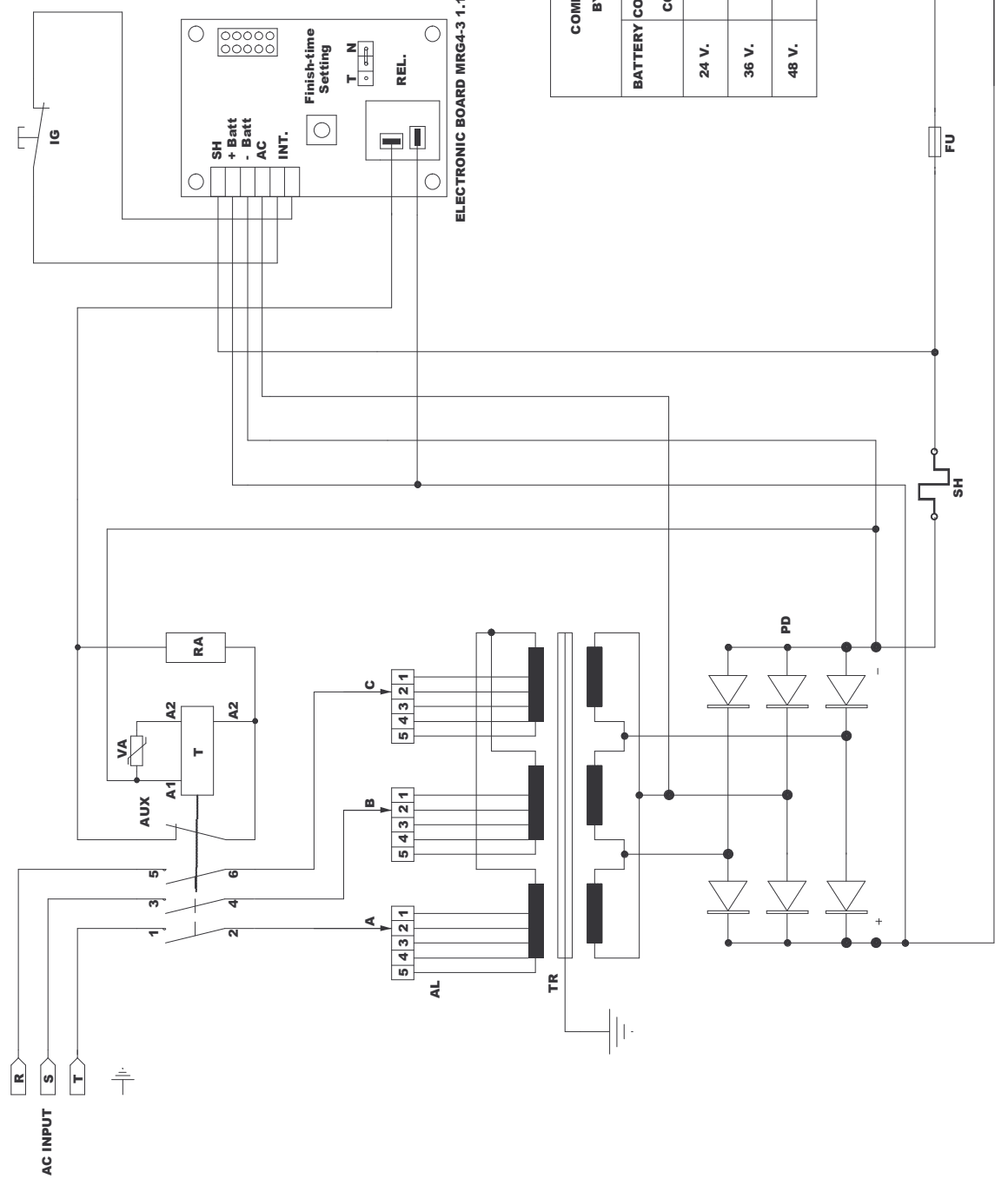

**COMPONENTS VALUE TABLE  
BY BATTERY VOLTAGE**

BATTERY	CONTACTOR	RA	AUX
	COIL VOLT		CONTACT
24 V.	24 V.	27 OHM	P
36 V.	48 V.	0 OHM	NP
48 V.	48 V.	120 OHM	P

P = PRESENT  
NP = NOT PRESENT

**Bassi Bruno elettromeccanica & C. S.n.c.**

**Via Mensa 3/2, 48020 S. Maria in Fabriago – Lugo (RA)**

**Tel +39 0545 995008 Fax +39 0545 995006**

[info@batterychargers.it](mailto:info@batterychargers.it)

---